

8000

*WhisperKOOL*  
*Extreme Series*

User's Manual

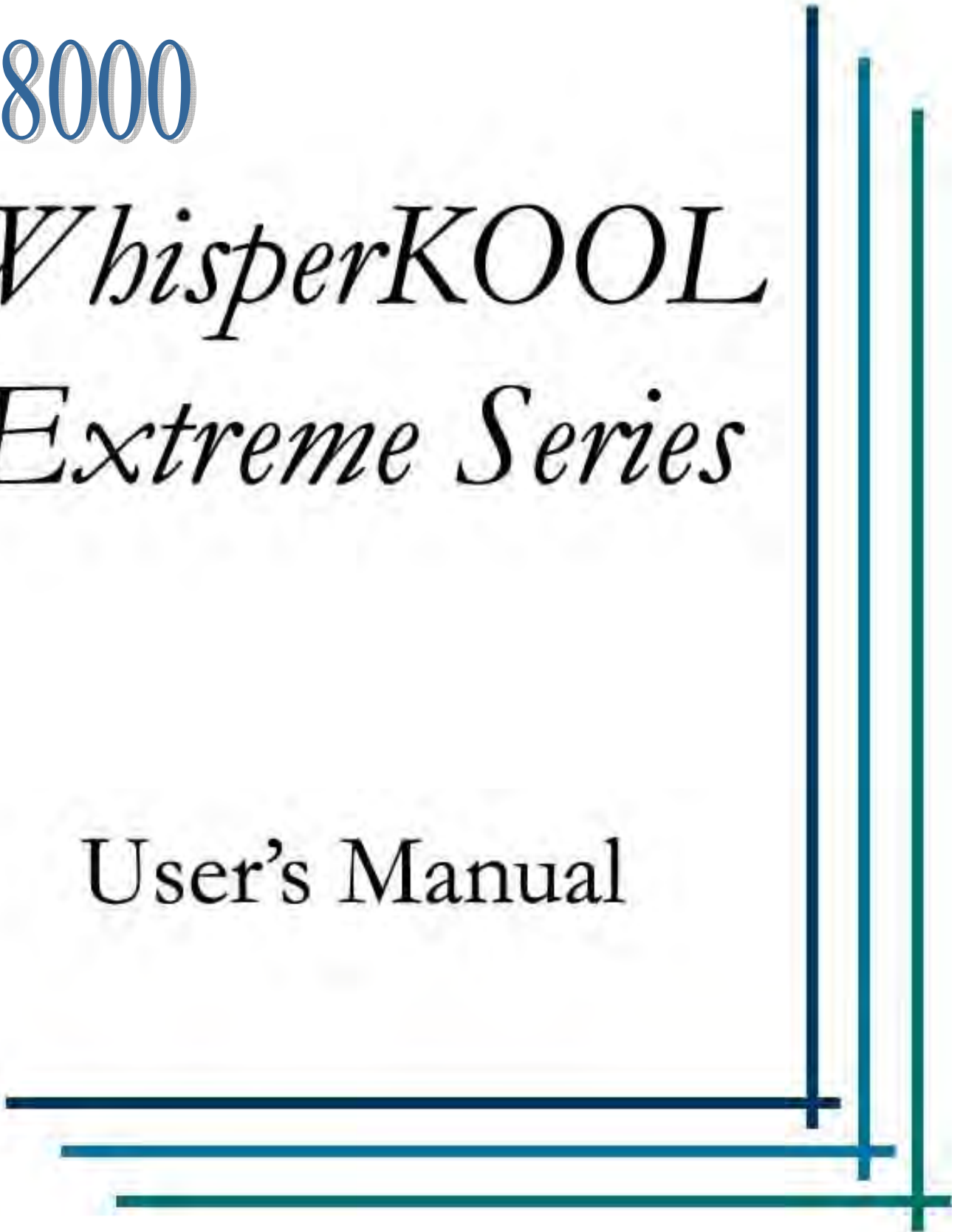



Copyright © 2007. Vinothèque Wine Cellars. All rights reserved.

This manual, the product design, and the design concepts are copyrighted by Vinothèque Wine Cellars, with all rights reserved. Your rights with regard to the hardware and manual are subject to the restrictions and limitations imposed by the copyright laws of the United States of America. Under copyright laws, this manual may not be copied, reproduced, translated, transmitted, or reduced to any printed or electronic medium or to any machine-readable form, for any purpose, in whole or in part, without the written consent of Vinothèque Wine Cellars.

Every effort has been made to ensure that the information in this manual is accurate. Vinothèque Wine Cellars is not responsible for printing or clerical errors.

Vinothèque Wine Cellars reserves the right to make corrections or improvements to the information provided and to the related hardware at any time, without notice.

Vinothèque and WhisperKOOL are registered trademarks, and ECE is a trademark of Vinothèque Wine Cellars. All rights reserved.

Mention of third-party products is for informational purposes only and constitutes neither an endorsement nor a recommendation. Vinothèque Wine Cellars assumes no liability with regard to the performance or use of these products.

Rev. 10-19 07



## Contents

<b>Introduction</b> .....	<b>7</b>
What Is the WhisperKOOL Extreme Cooling System?.....	7
How Does the WhisperKOOL Extreme System Work? .....	7
Temperature Setting.....	7
Features and Benefits .....	8
<b>Customer Warranty Registration</b> .....	<b>10</b>
Receiving and Inspecting the Unit.....	10
Review the Packing Slip to Verify .....	10
Check the Accessory Kits for the following contents: .....	11
<b>Preparing the Wine Cellar</b> .....	<b>12</b>
Wall & Ceiling Framing.....	12
Insulation .....	12
Vapor Barrier.....	13
Ducting.....	13
How to Build a Wine Cellar Instructional Video.....	13
<b>Installation</b> .....	<b>14</b>
Electrical Needs.....	14
Electrical Outlet .....	14
Sizing Unit to the Room.....	14
Condensation Drain Line Tube .....	14
Push Button Circuit Breaker .....	15
<b>Through-the-Wall Installation</b> .....	<b>16</b>
Test the Unit Prior to Installation .....	16
Mounting Flange Pieces.....	16
<b>Standard Mounting Arrangements</b> .....	<b>17</b>
Typical Through the Wall.....	17
Applying Insulation Tape.....	21
Placement of Unit.....	22
Location of Supply and Return Grilles.....	22
<b>Ducted Installation</b> .....	<b>23</b>
General Duct Recommendation.....	23
Using Ductwork.....	24
Cold Air to/from Wine Cellar .....	24
Warm Air to/from Wine Cellar.....	24
<b>Standard Ducted Installation</b> .....	<b>25</b>
Dual Outlet Duct .....	25
Outside through the Wall.....	25
Remote Mount on Floor .....	26
Outside Remote Mount.....	26
<b>Liquid Measuring Thermostat System</b> .....	<b>27</b>
<b>Thermostat Instructions</b> .....	<b>28</b>
<b>Maintenance Schedule</b> .....	<b>29</b>

<b>Troubleshooting Guidelines .....</b>	<b>30</b>
<b>Unit Does Not Come On .....</b>	30
<b>Unit Leaks Water .....</b>	30
<b>Cellar Temperature is too Cold .....</b>	31
<b>Cellar Temperature is too High.....</b>	31
<b>Technical Assistance .....</b>	<b>32</b>
<b>Installation Terms and Conditions.....</b>	<b>33</b>

## **-Introduction**

Congratulations and thank -you for purchasing a WhisperKOOL Extreme cooling unit. We believe it to be the best wine cellar cooling unit on the market.

This User's Manual is intended to assist in proper installation and maintenance of the WhisperKOOL Extreme cooling system. In order to ensure the longevity of your cooling unit, the equipment should be installed properly and have a proper care and maintenance schedule. Please read and review this manual carefully and keep for future reference.

### **What Is the WhisperKOOL Extreme Cooling System?**

The WhisperKOOL Extreme Series system is a specialized refrigeration unit designed for one purpose only: to maintain the optimal temperature and humidity levels conducive to the proper aging of fine wines. It is a self-contained cooling unit designed to be used as a free-blowing, through-the-wall unit or as a remote mount unit with external ductwork connections.

### **How Does the WhisperKOOL Extreme System Work?**

The WhisperKOOL Extreme System is divided into two sections: the evaporator or cooling section and the condenser or heat rejection section. Each section contains a coil to add or remove heat and a fan to move the air through the coil and into or out of the cellar or adjacent space. Air passes through the cooling coil and is cooled by the refrigerant inside the coil. This causes any excess humidity in the air to condense and be collected in the drain pan. Air then enters the fan where it is pressurized and discharged out of the unit. The thermostat, located on the unit inside the cellar, turns on the cooling unit as needed to maintain its set point (see thermostat instructions on page 28).

The compressor and condenser sections are activated whenever the unit is cooling. The condenser fan draws air from the surrounding or *ambient* space either directly or through a duct. The air is first drawn through a filter to remove any airborne dust particles to keep the coil clean. Then the air flows through the condenser coil where it absorbs heat from the refrigerant in the coil. The air is finally discharged out of the unit by the condenser fan.

### **Temperature Setting**

The WhisperKOOL Extreme unit can be set at any temperature within the acceptable wine-aging range of 50°F to 70°F. It is designed to cool 55°F cooler than the *ambient* temperature of the space to which it is exhausting.

## **Features and Benefits**

### **Liquid Temperature Measuring Probe**

The unit accurately measures the temperature of wine in the cellar using a liquid temperature measuring probe. Measuring the temperature of a liquid is a more direct and accurate reflection of the temperature of the wines stored in the cellar than measuring the ambient cellar air.

### **High Heat Alarm**

If the temperature on the back side of the unit reaches 130°F, a red indicator light will turn on. The light shuts off once the temperature lowers to 100°F.

### **Temperature Control**

This control enables the target wine temperature in the wine cellar to be set via the temperature of the liquid measured by the Liquid Measuring Probe. It is preset from the factory to 55°F, but can be adjusted to any temperature between 50°F and 70°F. A digital read-out displays the temperature in either Celsius or Fahrenheit (setting is selectable).

### **Frost Prevention Setting to Prevent Coil Freezing**

The unit contains a preset, automatic frost prevention feature that prevents any ice from building up on the coil. This allows the WhisperKOOL Extreme to operate effectively in demanding environments.

### **Refrigerant High Pressure Shut Off**

The automatic high pressure shut off feature is designed to protect the compressor from excessive head pressures. This protects the system in case there are any obstructions restricting air flow through the filters, duct, or grille.

### **Low Ambient Control System**

The system allows the condenser section (back of the unit) to be exposed to air temperatures as low as 0°F. It enables operation of the compressor and refrigerant systems when exposed to cold temperatures.

### **Remote Control Panel (optional)**

The system's control panel can be mounted remotely; that is, the control panel can be installed or mounted separately from the cooling unit itself. This option provides unique flexibility for installing the Extreme Series cooling unit in your wine cellar.



### **Superior Operating Flexibility**

The Extreme Series wine cellar cooling units are designed to work in conditions that cause traditional cooling units to fail. Engineered to solve the most difficult installation dilemmas, the Extreme Series has the performance capability to provide superior wine cellar temperature control:

- In hotter environments where cooling is difficult, up to 120°F;
- In cold areas where many units fail to operate.

### **Ducting and Ventilation Options**

The ventilation system is ideal for ducting. The optional collars fit standard ventilation ducting allowing the installer to vent air to and from the unit for optimum performance (please see specifications for details).

# Customer Warranty Registration

PLEASE COMPLETE AND RETURN THE WARRANTY CARD  
UPON RECEIPT OF THE UNIT.

By completing the Product Registration Card, you will be confirmed in our Customer Database ensuring that your information is on file to help you obtain efficient warranty service.

Please refer to pages 36-38 for complete terms and conditions, warranty guidelines, and policy for your WhisperKOOL Extreme Series Cooling Unit.

## Receiving, Inspecting, and Unpacking your WhisperKOOL Extreme Cooling Unit

### Receiving and Inspecting the Unit

**Note:** WhisperKOOL Extreme units are manufactured in the USA and tested prior to shipment.

- ✓ Lift at the designated handhold locations on the shipping container only or fully supported from underneath. A shipment may include one or more boxes containing accessories.
- ✓ Before opening the container, inspect the packaging for any obvious signs of damage or mishandling.
- ✓ Write any discrepancy or visual damage on the Bill of Lading before signing.
- ✓ Place the WhisperKOOL Extreme unit on a tabletop to prepare it for installation and testing.

### Review the Packing Slip to Verify

- ✓ The model number to ensure it is the correct size.
- ✓ All factory options ordered are listed.

If any items listed on the packing slip do not match your order information, contact Vinothèque Wine Cellars Customer Service immediately.

## **Check the Accessory Kits for the following contents:**

### Kit One:

- ✓ WhisperKOOL Extreme Series User's Manual
- ✓ Registration / Warranty Card

### Kit Two:

- ✓ Power Cord
- ✓ Self-Tapping Screws (6)
- ✓ Drain Line
- ✓ Mounting Flange Pieces (4)
- ✓ Bottle Temperature Probe
- ✓ Insulation Foam (4 strips)

Please leave the WhisperKOOL Extreme Unit in its original box until you are ready for installation. This will allow you to move the product safely and without damaging it. When you are ready to remove the product from the box, refer to page 14 for installation instructions.

**Note:** Save your box and all packaging materials. They provide the only safe means of transporting/shipping the unit.

# Preparing the Wine Cellar

The performance and life of your WhisperKOOL Extreme Series Unit are contingent upon the steps you take in preparing the wine cellar.

**Note:** Improperly preparing your enclosure or incorrectly installing your WhisperKOOL Extreme unit may cause unit failure, leaking of condensation, and other negative side effects.

## **IT IS HIGHLY RECOMMENDED THAT YOU OBTAIN THE ASSISTANCE OF A WINE STORAGE PROFESSIONAL.**

Wine storage professionals work with licensed contractors, refrigeration technicians, and racking companies to build well-insulated, beautiful, and protective wine cellars. Vinotheque Wine Cellars has put together some useful tips to assist in the installation process.

Our recommendations are meant to act as a guide in the process of building a proper enclosure. Your intended location may have specific needs that we do not address.

### **Wall & Ceiling Framing**

Build wine cellar walls using standard 2x4 or 2x6 construction methods and ceiling joists following the guidelines of local and state codes in your area. The general rule of a cellar is the thicker the walls and the higher the insulation factor, the better the cellar remains at a consistent temperature.

### **Insulation**

**Insulation is REQUIRED** with the use of the WhisperKOOL product. Standard “Fiberglass” or “Rigid Foam” insulation is normally used in cellar construction or, in some cases, “blown-in” insulation is used. It is very important that all walls and ceilings be insulated to keep the cellar temperature as consistent as possible during the summer and winter months. The R-factor, or quality of insulation, is determined by the rate at which heat passes through the insulation. The higher the R-factor, the more resistant the insulation is to conduct heat. Using higher R-values in insulation will result in lower operating costs and running times.

## Vapor Barrier

**Vapor Barrier is REQUIRED** to prevent the intrusion of water vapor, which keeps the cellar at the correct temperature and humidity. Six-mm plastic sheeting, recommended, is applied to the warm side of the cellar walls. The vapor barrier must be applied to the outside walls and ceiling. If it is impossible to reach the outside, then the plastic must be applied from within the cellar. The most common method is to wrap the entire interior, leaving the plastic loose in the stud cavity so the insulation can be placed between each stud. Insulation is installed before the vapor barrier. All of the walls and ceiling must be wrapped in plastic for a complete vapor barrier.

In areas of high humidity, such as Southern and Gulf States, the vapor barrier will prevent infiltration of warm moist air. The moist air can cause mold to form, and standing water in drain pans promote microbial and fungal growth that cause unpleasant odors and indoor air quality problems. If mold is found, remove it immediately and sanitize that portion of the unit.

## Ducting

The WhisperKOOL Extreme Series is designed so it can also be used with external ductwork connections. Ducting for the WhisperKOOL Extreme is sold in kits for each individual unit. Different kits are available to suit your specific needs. The number of duct kits you require will depend on your layout. Follow installation instructions carefully. Poorly or incorrectly installed ducts can degrade the performance of your unit dramatically.

## How to Build a Wine Cellar Instructional Video

Vinothèque Wine Cellars has a construction tutorial available on line at our website

**[www.vinotheque.com](http://www.vinotheque.com)** or you can call 1-800-343-9463 and contact our Customer Service (ext. 740) or Sales Department (ext. 730) for information on how to obtain a DVD version. This tutorial will walk you through the steps of constructing a properly built wine cellar and the installation of our WhisperKOOL product line.

# Installation

## Electrical Needs

The WhisperKOOL Extreme System requires a dedicated 115-volt 15-amp circuit. The unit draws a large amount of amps at initial start up. By designating a dedicated circuit breaker, you will guarantee the unit has enough power to run effectively. Contact your electrician for assistance with the installation of this dedicated electrical circuit.

Do:

- ✓ Match the electrical outlet to the plug provided on the WhisperKOOL Extreme Unit.
- ✓ Provide a dedicated circuit and wiring for the unit.
- ✓ Provide a weatherproof plug for units mounted outside.
- ✓ Mount outside units at a height of 18" and provide overhead protection.

## Electrical Outlet

The unit is equipped with two electrical outlets: one for the interior or cellar side and one for the exterior or outside of the cellar. There is a toggle switch located on the right side of the unit that indicates front (cellar side) and rear (exterior side). When placed in either position, power will come from that outlet only.

Purchase a surge protector or power conditioner in which to plug your WhisperKOOL Extreme System. As with any sensitive electrical equipment, the Extreme's electrical equipment may be damaged by power surges and spikes. Power surges and spikes are not covered in the WhisperKOOL Extreme warranty.

**WE RECOMMEND THAT YOU DO NOT USE A GROUND FAULT INTERRUPTER (GFI) WITH THIS PRODUCT.**

## Sizing Unit to the Room

Model	Cellar Volume (cubic feet)	AMPS (starting)	AMPS (running)	Product Dimensions (W X H X D)
8000 Extreme	2000	36	10	14.25" x 22.5" x 28"

## Condensation Drain Line Tube

The condensation drain line tube is used to remove excess condensation from the unit to a proper discharge location. It is important that the drain line tube be properly connected and used as to prevent leakage and other problems associated with excess condensation. Failure to use the condensation drain line tube will void the warranty on the unit.

## Push Button Circuit Breaker

In case the unit should lose power, press the reset button and attempt to turn unit back on. Check the home/main circuit breaker. If unit does not respond properly, refer to troubleshooting on page 32.

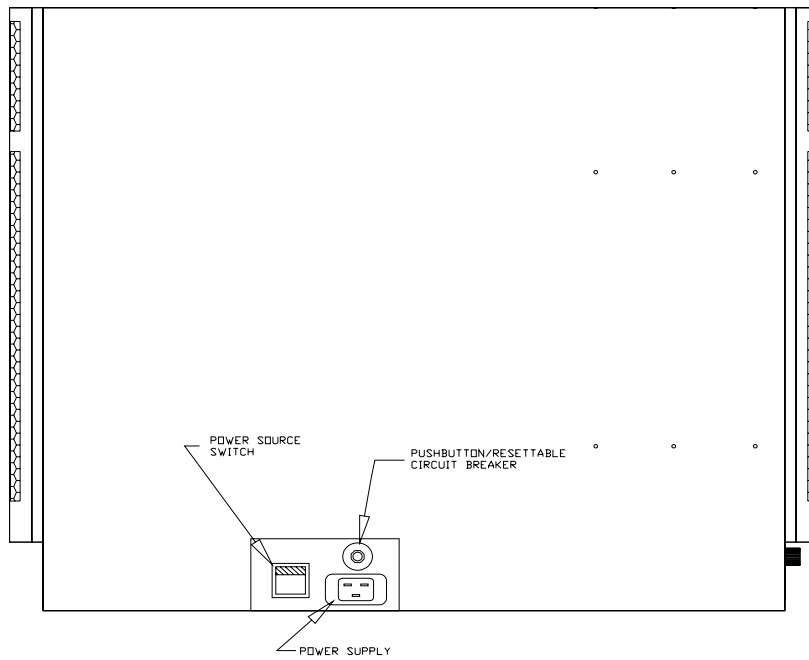

# Through-the-Wall Installation

(Without Ductwork)

## Test the Unit Prior to Installation

To prepare it for testing before installation in wall:

- ✓ Remove unit from box
- ✓ Place unit on tabletop
- ✓ Plug in unit to electrical outlet
- ✓ Plug in bottle sensor
- ✓ Turn on to test (Should be 12° across coils)
- ✓ Turn off after test
- ✓ Remove bottle sensor

## Mounting Flange Pieces

There are four individual pieces located in Kit 2 of your enclosed accessory kits. These flange pieces are designed to be used on the backside of the Extreme Series to mount to the exterior wall. There are three punch-outs located on the exterior of the housing. The punch-outs are designed for specific through-the-wall installation mounts. Please refer to the illustration for location of the punch-outs.

1. Retrofit your current WhisperKOOL cooling unit.
2. Middle wall installation.
3. Flush mount to exterior wall.

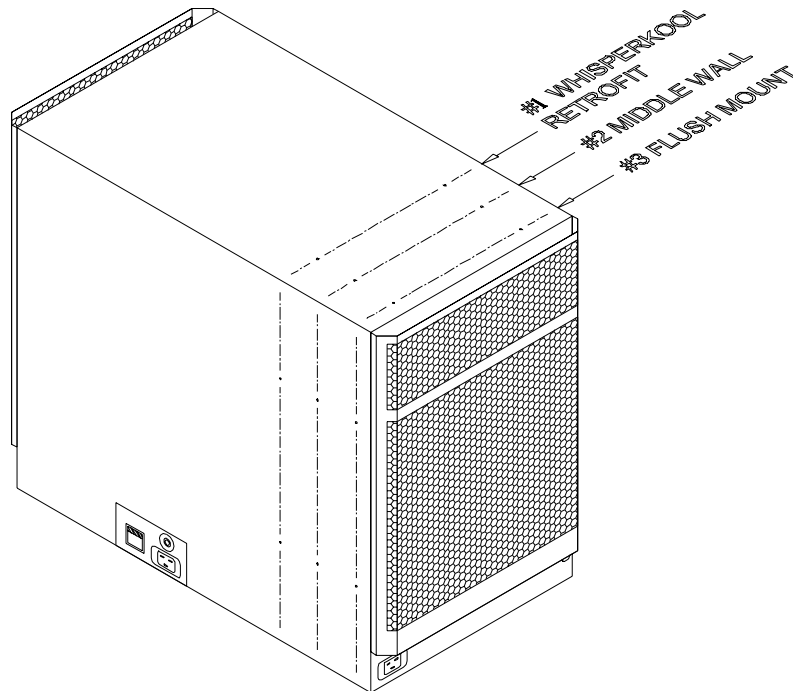



# Standard Mounting Arrangements

## Typical Through the Wall

These illustrations are suggested mounting styles and act as guidelines only. They do not represent the actual installation of the unit.

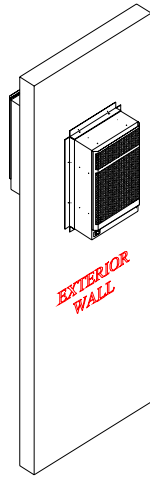

1. WhisperKOOL retrofit

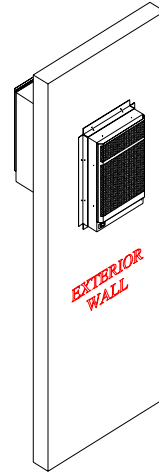

2. Middle Wall

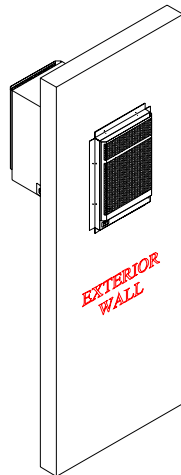

3. Flush to Exterior Wall

## Cutting the Hole for the WhisperKOOL Unit

### Tools Needed

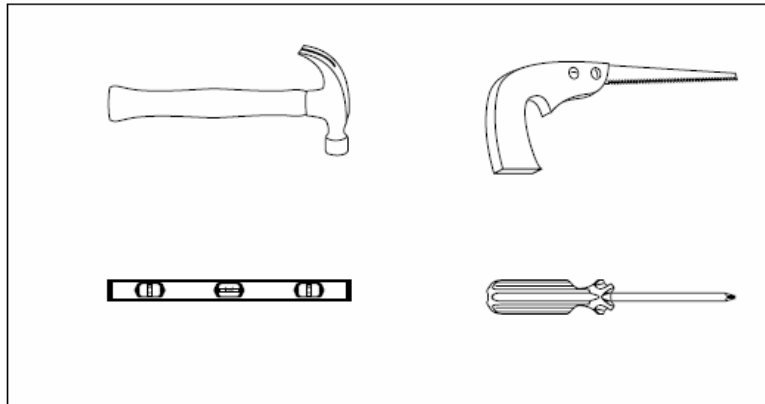

Locate the center of the wall upon which the unit will be installed. Using a stud finder, locate the stud on either side of the center point, and mark them with vertical lines.

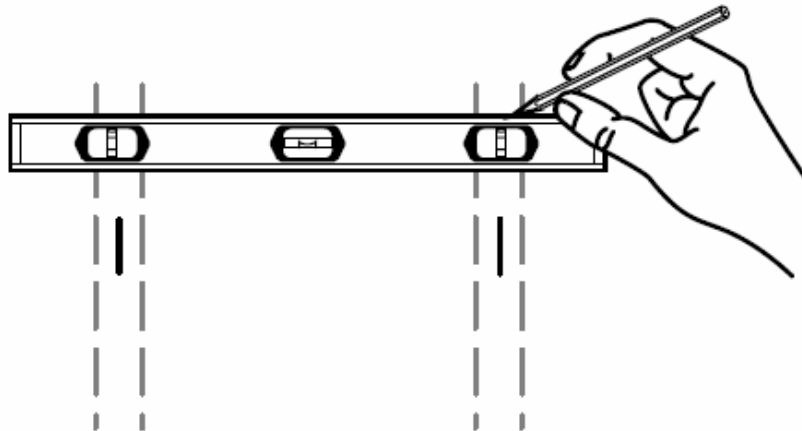

Using a level and a pencil, mark a horizontal line on the wall between the two studs, approximately 1.25" (or as close as possible if more than 1.25") from the ceiling.

Using a ruler or measuring tape, measure 22.75" down, and mark another horizontal line parallel to the first one.

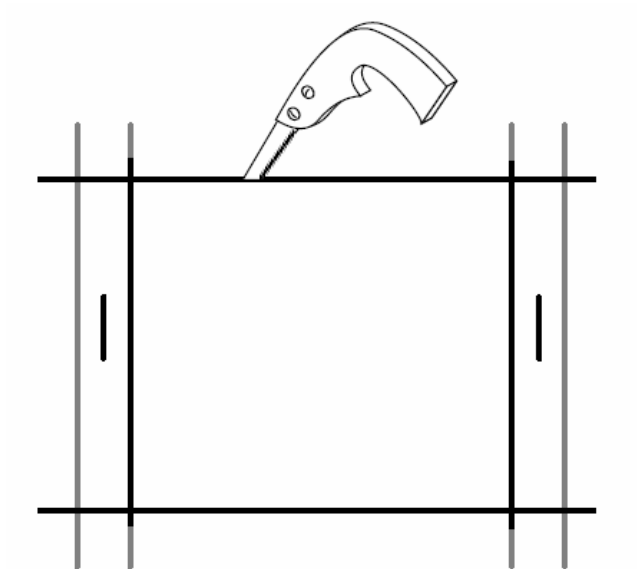

Using a saw, cut along the uppermost horizontal line until your saw reaches the stud. Turn the saw around, inserting it into the cut you have just made, and cut toward the opposite stud so that you have a clean horizontal cut between the two studs. Be careful not to cut into the studs themselves.

Now make the second horizontal cut from stud to stud on the line 22.75" below the first cut.

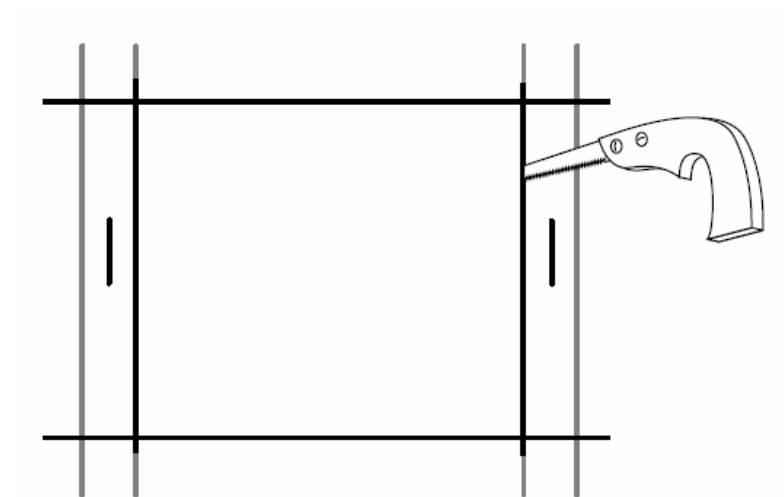

Once the horizontal lines have been cut, make vertical cuts using the inside edge of the studs as a guide. Once you have made both vertical cuts, you should have a rectangular hole in the sheetrock.

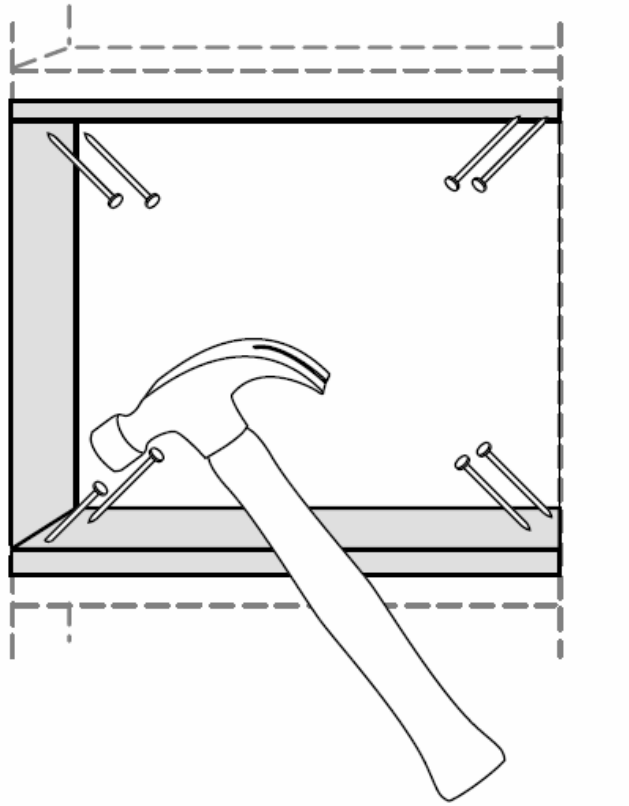

Now you have to make the same hole on the other side of the wall. Since you already have one hole, this is an easy process. Using a nail, mark all four corners of the first hole by making nail holes through the sheetrock. Then on the other side of the wall, connect the holes with a pencil mark and cut.

Sheetrock alone cannot support the weight of a 65-pound (or more) cooling system. Therefore, it is necessary to frame the hole that you have just cut with upper and lower supports.

Using two 2x4s 14.5" in length and eight 6d nails, secure the upper and lower supports to the right and left studs, just inside the sheetrock. Make sure that the internal height remains at 22.75" so that the WhisperKOOL system will fit snugly through the framed cut-out.

## Applying Insulation Tape

Locate the four precut pieces of black foam tape included with the system. There should be two larger pieces and two smaller pieces. Once you have attached the flange pieces to the unit, peel back the white-paper adhesive covering and place on the corresponding size of flange. The large pieces are applied to the top and bottom of the unit and the smaller pieces to the right and left side flanges. This foam creates a tight seal between the flange and the wall.

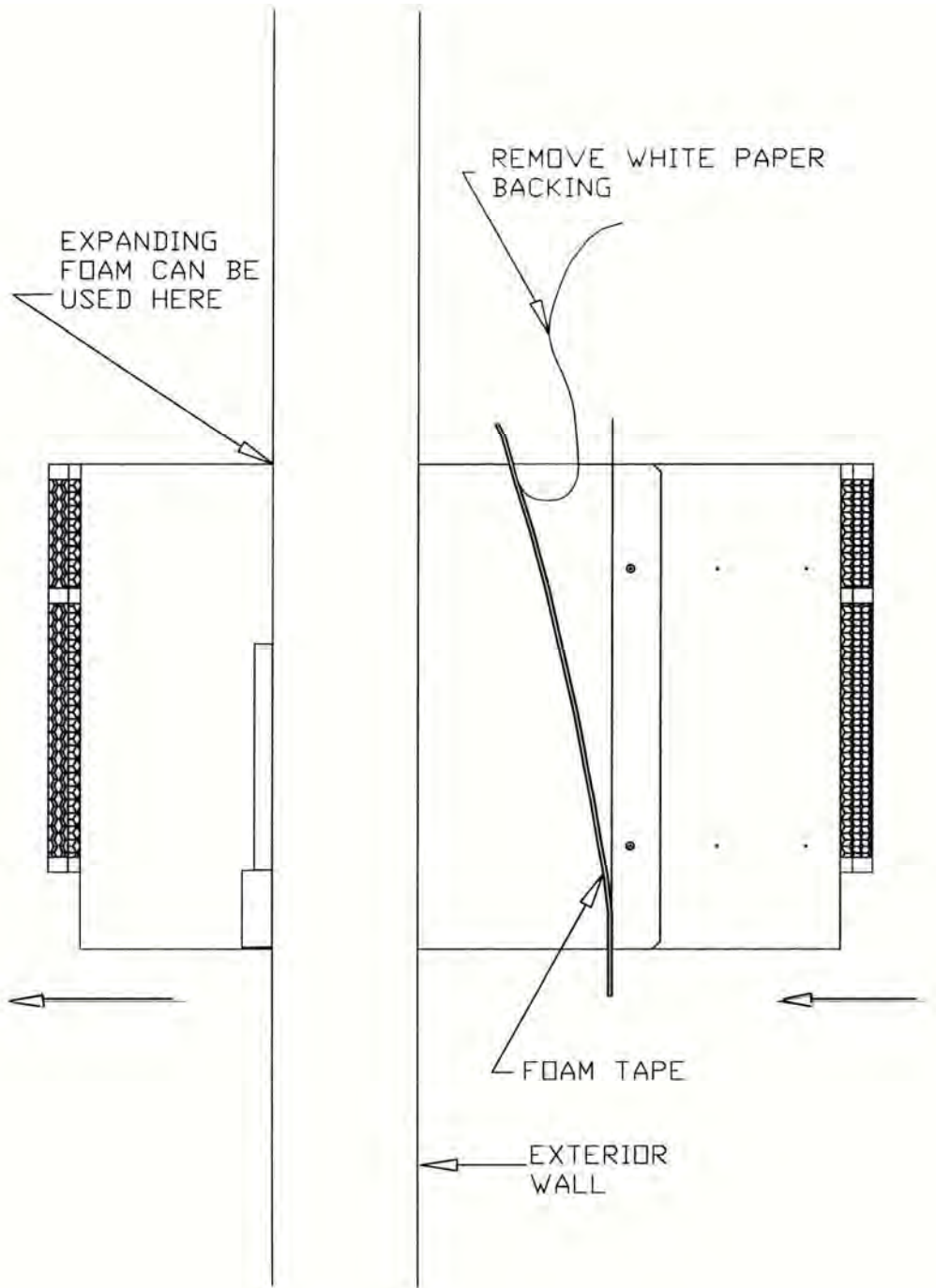

## Placement of Unit

Slide the unit from either the inside or outside wall into your wine cellar with the outer flange flush to the wall. You will need to reverse the mounting flange depending on inside or outside use. Secure the flange to the wall through the pre-drilled holes. The screws should penetrate the studs as well as the upper and lower supports to provide adequate support for the WhisperKOOL Extreme System (see illustration). Seal all cracks and gaps around the WhisperKOOL Extreme unit with an air tight sealant or caulking to prevent air leakage.

**Note:** If you use decorative molding, it should be attached to the walls and never to the cooling unit itself.

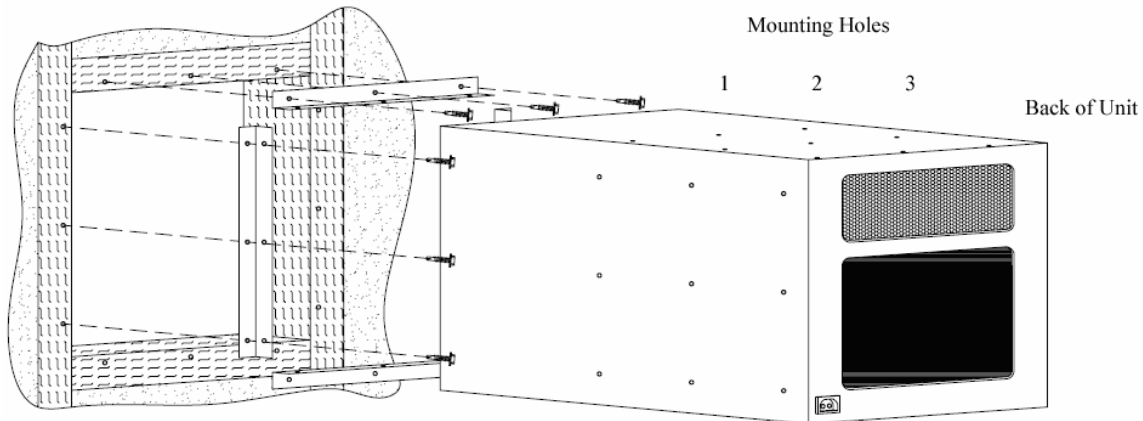

## Location of Supply and Return Grilles

Locate the supply and return grilles inside the cellar to create an airflow pattern that maximizes air circulation in the room. Avoid short circulation of the air.

### Do not:

- ✓ Install through-the-wall return air grilles at floor level, as they will collect dust from the floor.
- ✓ Mount the unit lower than 18" from the top of the room.
- ✓ Locate the supply or return air grille where it is blocked by bottles, boxes or cases.

# Ducted Installation

Use ductwork to connect the unit to the supply and return outlets in the wine cellar. Use only insulated ductwork to minimize cooling losses, prevent sweating, and reduce noise.

Use ductwork on the condenser section to redirect or absorb sound, bring in outside air to the unit inlet, and/or exhaust the hot air out of the ambient space.

**Note:** Do not exceed a total of 25' for each length of ductwork run and a total of 50' combined for both the supply and return lengths.

Avoid crimping the flexible ducts. This chokes down the inside area and reduces the airflow causing the unit to operate erratically.

Be sure all ducts and surfaces in contact with the airflow are insulated and have a vapor barrier on the outside.

**Uninsulated ducts and surfaces cause bare, exposed metal surfaces to sweat, further degrading the insulation and equipment cooling capacity.**

## General Duct Recommendation

- ✓ Provide support for the flexible duct to prevent sags and bends.
- ✓ Stretch out the duct to make a smoother interior, which reduces air resistance.
- ✓ For 90° bends, use a 90° adjustable elbow (Ell).
- ✓ Do not squeeze or reduce the inside diameter of the ducts which reduces airflow.
- ✓ Use short and straight ductwork where possible.
- ✓ Remove the grilles and panels from the openings to connect the ductwork.
- ✓ Check that all fan blades move freely.
- ✓ Keep air paths free of loose foreign objects and debris.
- ✓ Connect the round flexible ducts to the WhisperKOOL Extreme using the duct collars provided with the duct accessory kit.
- ✓ Pull the outer plastic wrapping and insulation away from the end of the duct to expose the reinforced inside duct liner.
- ✓ Fasten the duct collar using tie straps or clamps around the inside liner.
- ✓ Secure the duct collar to the unit using the screws provided. Take care to not damage or bend the gasket.
- ✓ Use approved duct tape to seal all joints.

**Do not clamp around the outside insulation. It compresses and loosens over time.**

## **Using Ductwork**

### **Cold Air to/from Wine Cellar**

- ✓ Remove supply air grille to install ductwork between WhisperKOOL Extreme unit and the cellar.
- ✓ Connect the supply air ductwork from the cellar to the supply air outlet adapter flange at the WhisperKOOL Extreme unit.
- ✓ Connect the return air ductwork from the cellar to the return air inlet adapter flange at the WhisperKOOL Extreme unit.

### **Warm Air to/from Wine Cellar**

- ✓ Connect ductwork on the condenser to direct heat and air noise away from occupants.
- ✓ Connect ductwork to another space within the basement or out of the building if exhausted heat is undesirable.



# Flexible and Easy Installation

## Fully Ductable System

The ventilation system is ideal for ducting. The optional collars fit standard ventilation ducting allowing the installer to vent air to and from the unit for optimum performance (please see specifications for details).

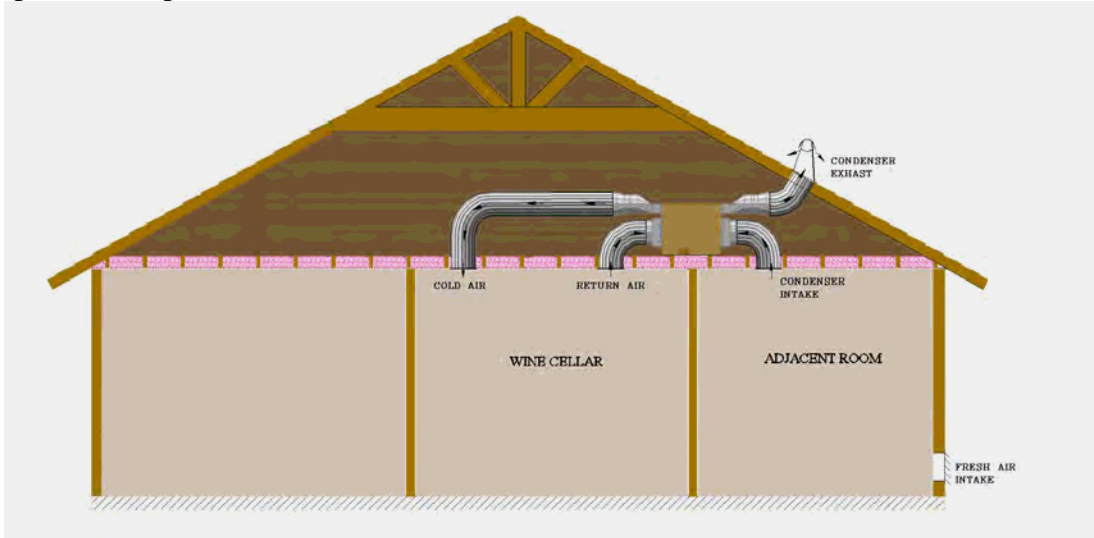

## Outside The Cellar

Ducting to and from the unit to the cellar in a variety of configurations, results in a virtually noise free cellar for entertaining and enjoying your investment.

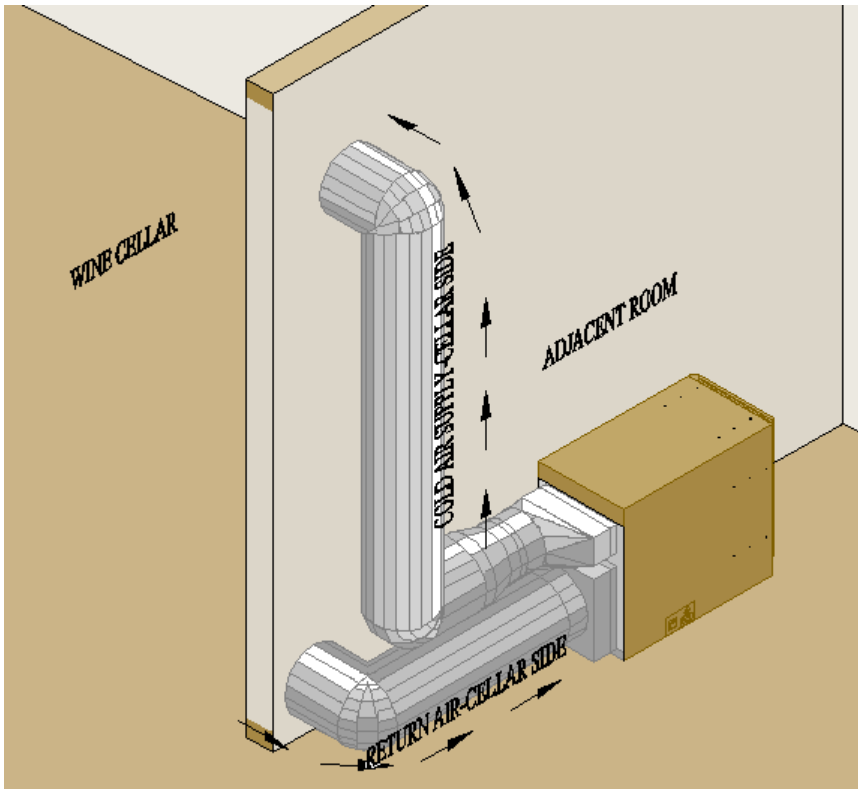

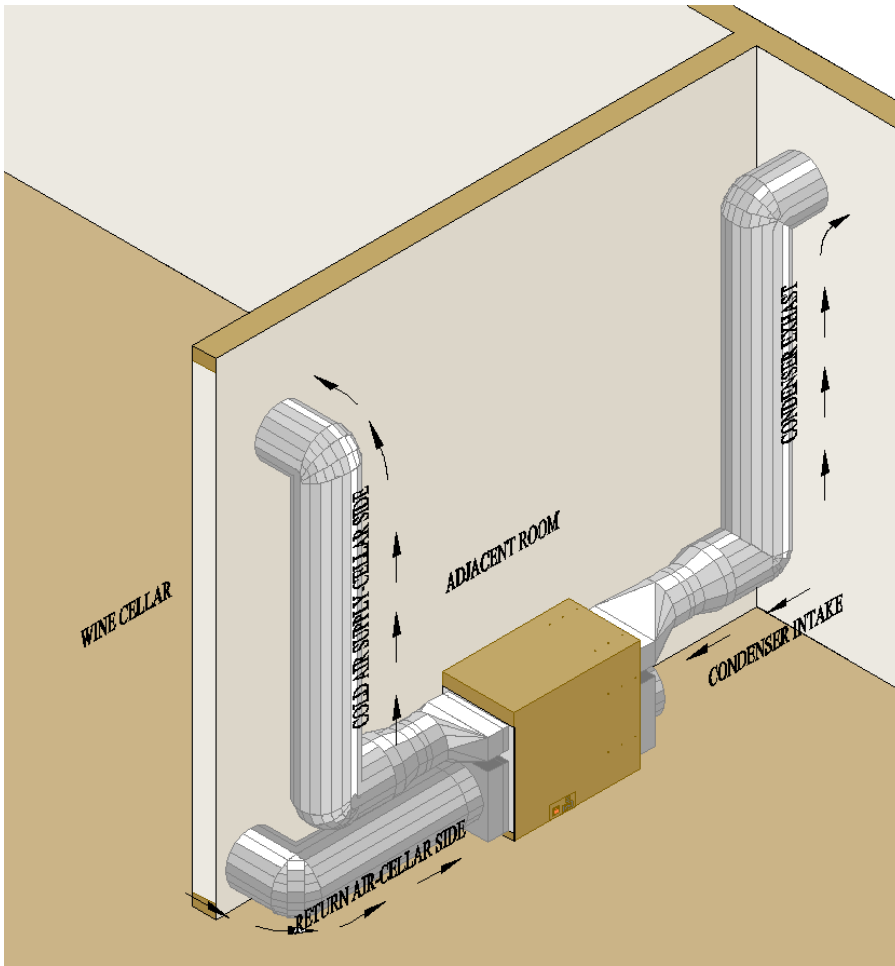

# Liquid Measuring Thermostat System



## **Power Switch**

Turns the unit on/off.

## **Hi-Pressure Light**

Lights red when the refrigerant pressure is too high. Turn the power off and then turn back on to reset.

## **Bottle Sensor**

Indicates where to attach the bottle sensor probe.

## **Temperature Read-Out**

See following pages for Temperature Read-out information.

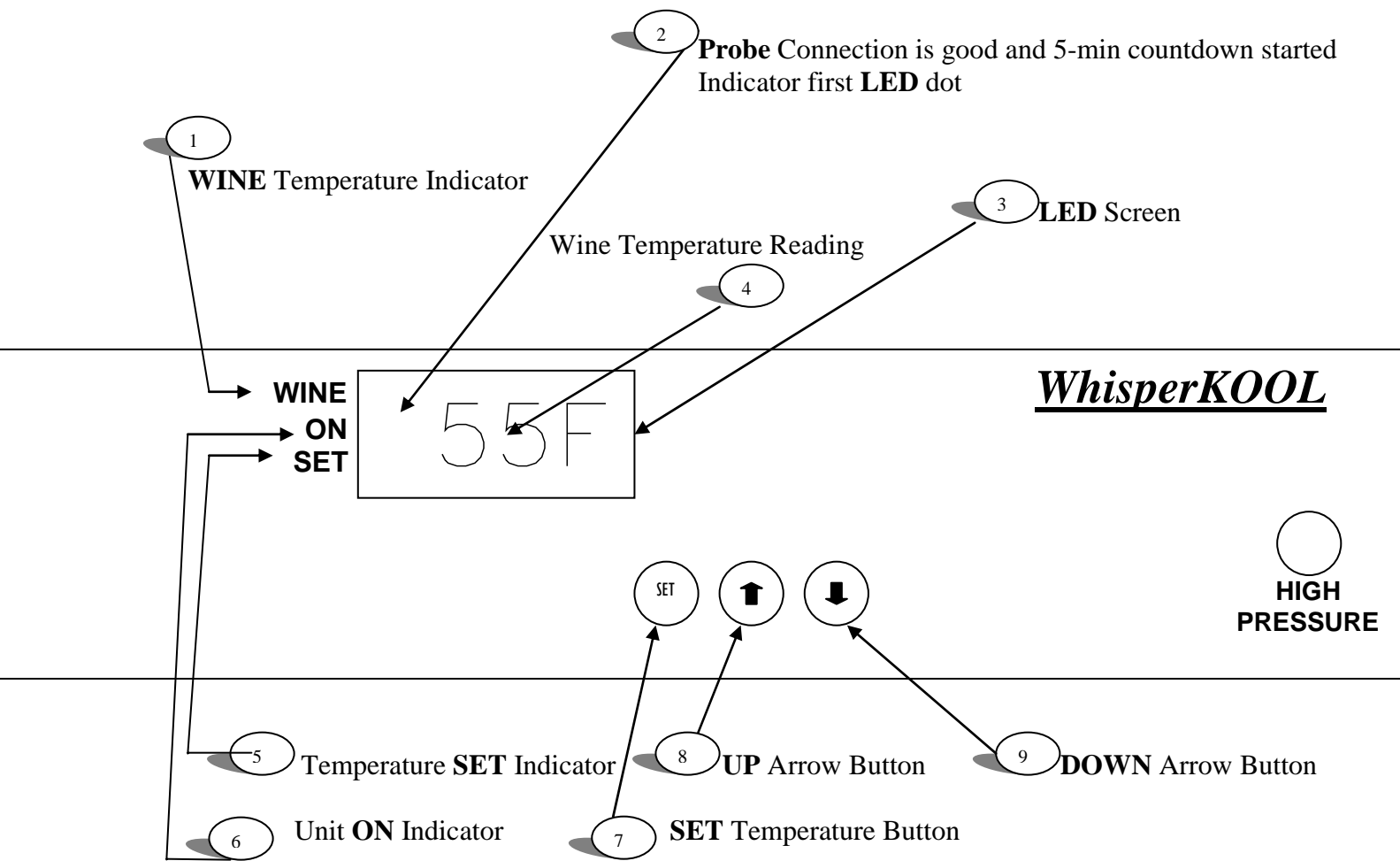

1. **Wine Temperature Indicator:** A red LED bar will light up when the thermostat is reading the liquid temperature in the bottle via the probe. This will remain lit and the temperature you see displayed is what the probe is reading.
2. **Probe Connection:** Indicator lights up with a little red dot; this will remain lit while the 5-minute countdown is in sequence.
3. **LED Screen:** Displays your thermostat readings.
4. **Wine Temperature Reading:** The temperature reading the probe in the bottle of water is registering to the thermostat, which then displays that number to you.
5. **Temperature SET Indicator:** A red LED bar will light up when you are setting the temperature you wish to keep your wine collection at.
6. **Unit ON Indicator:** A red LED bar will light up every time the unit turns on to run a cooling cycle.
7. **SET Button:** Used to set the temperature you want the unit to maintain.
8. **UP Arrow Button:** Used with the SET button to set temperature higher. Also by pressing and holding button it will allow you to see the 5-minute count down.
9. **DOWN Arrow Button:** Used with the SET button to set temperature lower.

**\*Up and Down Arrow Buttons used simultaneously will change the temperature read out from Fahrenheit to Celsius\***

# Maintenance Schedule

Monthly	<ol style="list-style-type: none"><li>1. Check Filters</li><li>2. Check for unusual noise or vibration.</li></ol>
Quarterly	<p>Clean Filters:</p> <ol style="list-style-type: none"><li>1. Remove grille/ducting on both ends of unit.</li><li>2. Remove the filter covering the coil.</li><li>3. Wash with warm water</li><li>4. Dry off filter by shaking excess water from filter.</li></ol>
Yearly	<ol style="list-style-type: none"><li>1. Replace filters if worn or plugged beyond cleaning.</li><li>2. Use a vacuum with brush attachment to clean coils. Be careful not to crush coil fins when cleaning.</li><li>3. Inspect for corrosion.</li><li>4. Check wiring connections and integrity of cords.</li><li>5. Examine duct work for cracks or possible leaks.</li></ol>

# Troubleshooting Guidelines

## Unit Does Not Come On

Controller Display Panel Light is Not On	
<i>Possible Cause</i>	<i>Solution</i>
Unit is not plugged in Plug not correct on unit	Make sure power cord is plugged into outlet. Make sure the cord location and switch are both designating same plug (i.e. rear plug is switched on when cord is plugged into that outlet).
Power switch not on	Turn unit on with toggle switch on controller
No power to outlet	Reset circuit breaker on unit by pushing reset button located on right side of unit above the plug outlet.
No power to unit	Locate the WhisperKOOL dedicated circuit breaker in the home's main circuit panel. Push breaker firmly to the off position and then reset by pushing firmly to the on position.

## Unit Leaks Water

Water is Leaking from Unit	
<i>Possible Cause</i>	<i>Solution</i>
Unit is not level	Unit should be level in wall to prevent leaking.
Drain line is needed	Your unit was shipped with a drain line and brass fitting. If you are in a high humidity area, you need to install the drain line for excess condensation that may occur from excessive moisture introduced into the air.
Possible Heater Failure	Contact Customer Service

## Cellar Temperature is too Cold

Temperature is too Low when Unit is ON

*Possible Cause*

Controller set too low

*Solution*

Change set point on controller to higher temperature.

(Note: controller is programmed at 55°F when assembled at the factory)

Temperature is too Cold When Unit is OFF

*Possible Cause*

Too much heat lost to adjacent areas.

*Solution*

Add more insulation around ductwork and ensure doorways and glass panels are sealed.

## Cellar Temperature is too High

Temperature too High

*Possible Cause*

Controller set too high

*Solution*

Change set point on controller to lower temperature.

(Note: controller is programmed at 55°F when assembled at factory)

Not enough airflow from evaporator

Check for blockage in supply or return ductwork.

Check and clean filter and coil if needed.

Confirm room size

Measure square footage of room and confirm the unit being used is correct size for room.

Door seal

Make sure that you are using a high quality door seal. If there is a gap between the bottom of the door and the floor, the cool air will sink and flow out beneath the door.

# Technical Assistance

Vinothèque Customer Service is available Monday through Friday from 8:00AM to 4:00PM Pacific Time.

The customer service representative will be able to assist you with your questions and warranty information more effectively if you provide them with the following;

- ✓ The model and serial number of your WhisperKOOL Extreme Series Unit.
- ✓ Location of unit and installation details, such as ventilation, ducting, construction of your wine cellar, and room size.

## ❖ How to Contact Vinotheque Customer Service

Telephone	(209) 466-9463	(800) 343-9463
Fax	(209) 466-4606	
Website	<a href="http://www.vinotheque.com">www.vinotheque.com</a>	
Address	Vinothèque Wine Cellars 1738 E. Alpine Avenue Stockton, CA 95205	



# Installation Terms and Conditions

## WhisperKOOL XLT/Extreme Cooling System

ATTENTION: PLEASE READ THESE TERMS OF USE CAREFULLY BEFORE INSTALLING YOUR WhisperKOOL XLT/Extreme Cooling System. INSTALLING YOUR WhisperKOOL XLT/Extreme Cooling System INDICATES THAT YOU ACCEPT AND AGREE TO EACH OF THE TERMS AND CONDITIONS SET FORTH HEREIN ("TERMS OF USE"). IF YOU DO NOT ACCEPT THESE TERMS OF USE, YOU RISK VOIDING YOUR WARRANTY AND ASSUMING ADDITIONAL REPAIR AND REPLACEMENT COSTS.

### 1. Acceptance of Terms and Conditions

Use and installation of a WhisperKOOL XLT/Extreme Cooling System assumes that the consumer, ("user") fully accepts and agrees to the Terms and Conditions set forth in this document. The Terms and Conditions also state that, by signing and returning this document, you are certifying you have read, understood, and agreed to our Terms and Conditions, as well as our User's Manual. The User's Manual is shipped with each unit and, if another copy is needed, replacement copies can be downloaded from the company website ([www.vinotheque.com](http://www.vinotheque.com)) or by contacting Vinothèque Wine Cellars ("Vinothèque") directly for a new copy. Vinothèque reserves the right, in its sole discretion, to change its Terms and Conditions at any time, for any reason, without notice.

### 2. Product Installation

Subject to these Terms and Conditions, when the user purchases a WhisperKOOL XLT/Extreme Cooling System, the user agrees to read and follow the required installation procedures set forth by Vinothèque for proper use and installation of the Product.

- (a) It is highly recommended that you obtain the assistance of a wine storage professional.
- (b) Failing to address all of the variables associated with proper installation will cause the unit to operate incorrectly and limit its ability to cool and the longevity of the unit itself.
- (c) The warranty card must be returned to Vinothèque, the manufacturer, to ensure registration guaranteeing the full warranty period is granted. Failure to register the product within thirty (30) days of installation may result in a loss of warranty.
- (d) The user is responsible for the full costs of installation and any additional parts required for the proper and complete installation of the Product.
- (e) The WhisperKOOL XLT cooling system cannot operate at its optimum capacity if airflow is constricted by ducting or venting the exhaust side of the unit into a location with inadequate ventilation.

### 3. Product Warranty Information

If a problem arises with your WhisperKOOL system during the warranty period, you must contact Vinothèque Customer Service for warranty coverage and repairs.

Removing the rivets from the unit housing without authorization from the manufacturer will VOID the warranty. Please contact a customer service representative for assistance before beginning work on a WhisperKOOL unit that is still under the two (2) year manufacturer warranty

For XLT/Extreme Cooling Systems returned to Vinothèque following warranty guidelines, Vinothèque warrants this product against defects in material or workmanship as follows:

- (a) LABOR: For a period of two (2) years from the date of purchase. If this Product is found to be defective after undergoing customer service troubleshooting, Vinothèque will repair or replace the product, at its option and discretion, at no charge to the customer. After the Warranty Period, the customer is responsible for ALL labor and freight charges.
- (b) PARTS: Vinothèque will supply, at no charge, new or rebuilt replacement parts in exchange for defective parts for a period of two (2) years.
- (c) FREIGHT: During the first two (2) years from the date of purchase, Vinothèque will cover freight for the repair of units UNDER WARRANTY to customers within the continental United States.

This warranty does not cover cosmetic damage caused during installation or damage due to acts of God, accident, misuse, abuse, negligence, or modification to any part of the product. This warranty does not cover damage due to improper operation or lack of proper maintenance, connection to improper voltage supply, or attempted repair by anyone other than a technician approved by Vinothèque to service the product. This warranty does not cover products sold "AS IS" or "WITH ALL FAULTS." This warranty is valid only in the continental United States.

Proof of purchase in the form of a bill of sale or receipted invoice, which is evidence that the product is within the warranty period, must be presented to obtain warranty service.

This warranty is void if the factory-applied serial number has been altered or removed from the product.

REPAIR OR REPLACEMENT AS PROVIDED UNDER THIS WARRANTY IS THE EXCLUSIVE REMEDY OF THE CONSUMER. VINOTHÈQUE SHALL NOT BE LIABLE FOR ANY INCIDENTAL OR CONSEQUENTIAL DAMAGES FOR BREACH OF ANY EXPRESS OR IMPLIED WARRANTY ON THIS PRODUCT. EXCEPT TO THE EXTENT PROHIBITED BY APPLICABLE LAW, ANY IMPLIED WARRANTY OF MERCHANTABILITY OR FITNESS FOR A PARTICULAR PURPOSE ON THIS PRODUCT IS LIMITED IN DURATION TO THE DURATION OF THIS WARRANTY.

Some states do not allow the exclusion or limitation of incidental or consequential damages, or allow limitations on how long an implied warranty lasts, so the above limitations or exclusions may not apply to you.

This warranty gives you specific legal rights and you may have other rights which vary from state to state.

#### 4. Maintenance

It is the user's responsibility to remove any accumulated dust, lint, or other debris from the front and rear intake grilles. This will restrict the airflow and may affect the unit's ability to function properly.

Periodically cleaning the unit's vents will help assure maximum cooling efficiency. The drain tube must also be checked and kept clean and free of debris and mold to maintain proper performance.

Mold is a natural living organism in the environment. It exists in the air in the form of microscopic spores that move in and out of buildings through doors, windows, vents, HVAC systems and anywhere else that air enters. Once it is discovered, mold must be addressed quickly and appropriately. Delayed or improper treatment of mold issues can result in costly and recurring repairs. If you suspect you have a mold problem, it is always best to hire a qualified and experienced mold remediation specialist.

#### 5. User Costs and Responsibility

The following items are not covered under warranty and are the sole responsibility of the user.

- (a) The user is responsible for ALL initial installation costs, including, but not limited to, labor costs and the cost of any additional parts necessary to complete the installation.
- (b) The user is responsible for the costs incurred for installation and removal of the product or any part thereof unless it has been defined as a warranty repair PRIOR to the work being performed.
- (c) Purchasers (users) are reminded that they should satisfy themselves that the product they are purchasing is suitable for their needs and requirements and no responsibility will be placed with Vinothèque for their decisions.
- (d) It is the user's responsibility to secure safe haven/storage for ANY AND ALL items that are being kept and stored in the user's wine cellar. Vinothèque takes no responsibility for the safety and preservation of the aforementioned items in the event that the environment becomes unsuitable for proper storage.

#### 6. State Sales Tax

We collect California Sales Tax only for orders made and shipped within California. We do not collect sales tax for orders shipped to other states. However, you may be liable for sales tax to your state for the merchandise you receive. You may want to check with your state's tax authority for "use tax" regulations.

#### 7. Customer Service

Vinothèque's customer service department is available Monday through Friday, from 8:00AM to 4:00PM PT by calling 1-800-343-9463.

#### 8. Trouble Shooting

The customer service department is available to answer any questions or inquiries regarding our product as well as to assist in basic and primary troubleshooting for any problems with our product.

#### 9. General Provisions

(a) Construction and severability. Every provision of these Terms and Conditions will be construed, to the extent possible, so as to be valid and enforceable. If any provision of these Terms and Conditions so construed is held by a court of competent jurisdiction to be invalid, illegal or otherwise unenforceable, such provision will, to the extent so held, be deemed severed from these Terms and Conditions, and all other provisions will remain in full force and effect.

(b) Governing Law/Choice of Forum. The laws of the State of California (without regard for conflicts of law) shall govern the construction and enforcement of these Terms and Conditions, except that the Terms and Conditions shall be interpreted as though drafted jointly by Vinotheque and the Purchaser. Any dispute will be resolved in a state or federal court situated in the County of Santa Clara, State of California, and the Purchaser hereby irrevocably submits to the personal jurisdiction of such courts for that purpose.

(c) Entire Agreement/No Waiver. These Terms and Conditions and the Limited Warranty incorporated herein by reference set forth the entire agreement between the parties and supersede all prior agreements or understandings, both written and oral, between the parties regarding the subject matter of this the Terms and Conditions and the Limited Warranty. The parties may modify these Terms and Conditions or the Limited Warranty only in a writing signed by each. No waiver by Vinothèque of any breach or default hereunder will be deemed to be a waiver of any preceding or subsequent breach or default.

(d) Correction of Errors and Inaccuracies. These Terms and Conditions may contain typographical errors or other errors or inaccuracies. Vinothèque reserves the right to correct any errors, inaccuracies or omissions, and to change or update these Terms and Conditions, at any time, without prior notice.

#### 10. Questions or Additional Information

If you have any questions regarding these Terms and Conditions or wish to obtain additional information, contact us via phone at 1-800-343-9463 or please send a letter via U.S. Mail to:

Vinothèque Wine Cellars  
1738 E. Alpine Ave  
Stockton, CA 95205





Vinotheque Wine Cellars  
1738 E. Alpine Avenue  
Stockton, CA 95205  
800-343-9463